

SPARE PARTS SECTION

Shrinker Stretcher

Model. SHST1.2HO

Order Code S2264

Edition No : SHST1.2HO-1

Date of Issue : 02/2021

The following section covers the spare parts diagrams and lists that were current at the time this manual was originally printed. Due to continuous improvements of the machine, changes may be made at any time without notification.

HOW TO ORDER SPARE PARTS

1. Have your machines **model number, serial number & date of manufacture** on hand, these can be found on the specification plate mounted on the machine
2. A scanned copy of your parts list/diagram with required spare part/s identified.

NOTE: SOME PARTS MAY ONLY BE AVAILABLE AS AN ASSEMBLY

3. Go to www.machineryhouse.com.au/contactus and fill out the inquiry form attaching a copy of scanned parts list.

CONTENTS

Spare Parts Diagram.....	16
Spare Parts List.....	17

SPARE PARTS DIAGRAM

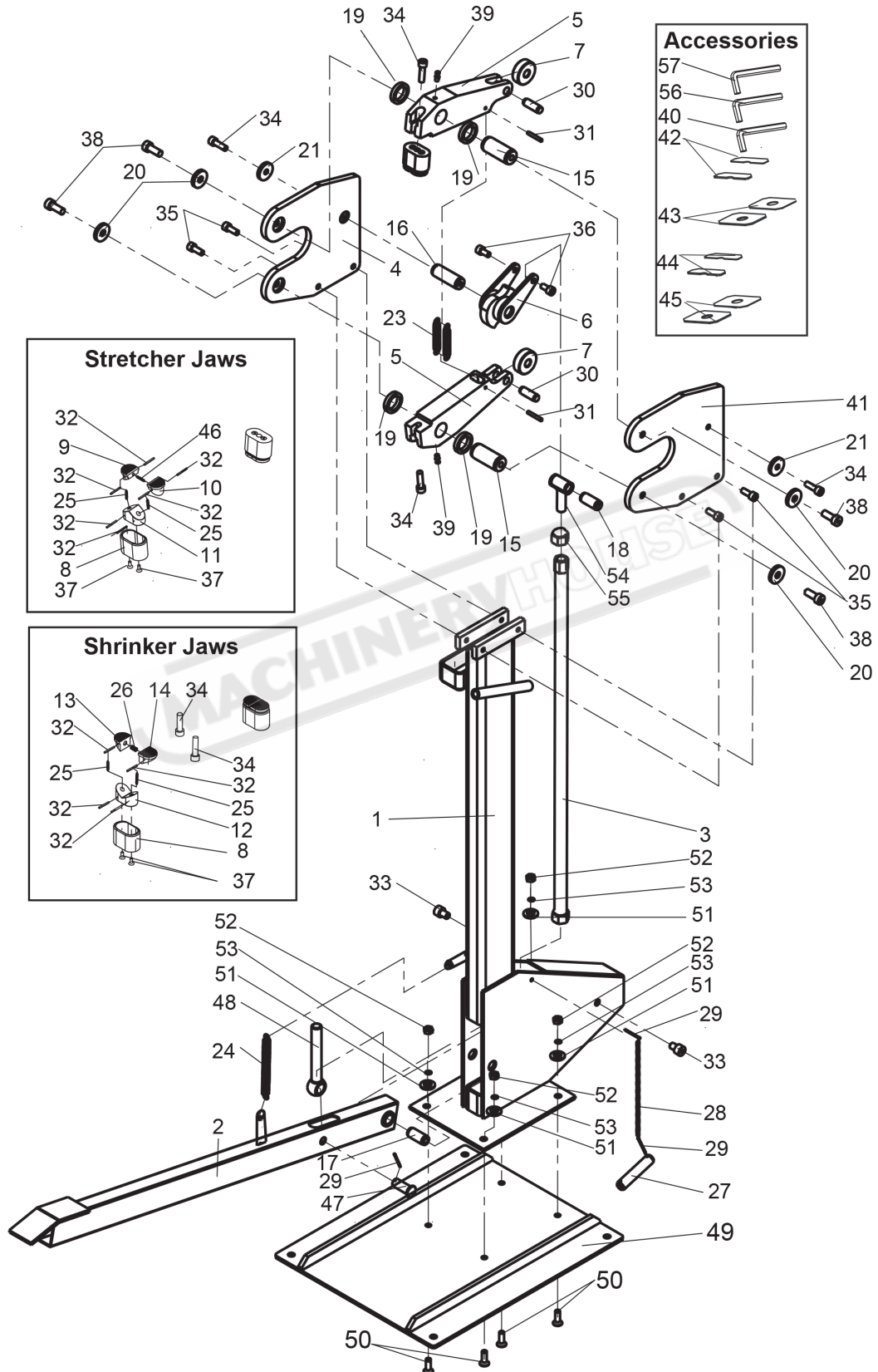

SPARE PARTS LIST

ITEM	DESCRIPTION	QTY.	ITEM	DESCRIPTION	QTY.
1	Frame	1	30	Pin 12mm	2
2	Footplate Bar	1	31	Pin 4mm	2
3	Bar	1	32	Pin 2.5mm	20
4	Left Side Support	1	33	Screw M10×16	2
5	Jaw Base	2	34	Screw M8×20	6
6	Driving Wheel	1	35	Screw M8×25	4
7	Driven Wheel	2	36	Screw M8×16	2
8	Jaw Cover	4	37	Screw M5×10	8
9	Stretcher Jaw 1	2	38	Screw M10×20	4
10	Stretcher Jaw 2	2	39	Lubricating Nipple	2
11	Stretcher V-Block	2	40	Wrench 6mm	1
12	Shrinker V-Block	2	41	Right Side Support	1
13	Shrinker Jaw 1	2	42	0.5mm Half Shim	2
14	Shrinker Jaw 2	2	43	0.5mm Whole Shim	2
15	Shaft 25mm	2	44	1mm Half Shim	2
16	Shaft 20mm	1	45	1mm Whole Shim	2
17	Shaft 16mm	1	46	Spring	2
18	Shaft 16mm	1	47	Pin	1
19	Washer 25mm	4	48	Bolt M16×120	1
20	Washer 10mm	4	49	Bottom Plate	1
21	Washer 8mm	2	50	Screw M8X25	4
23	Spring	2	51	Washer 8mm	4
24	Spring	1	52	Nut M8	4
25	Spring	8	53	Spring Washer 8mm	4
26	Spring	2	54	"T" Bolt	1
27	Pin 16mm	1	55	Nut M16	1
28	Chain	1	56	Wrench 5mm	1
29	Pin 4mm	3	57	Wrench 8mm	1

NOTE: SOME INDIVIDUAL PARTS MAY ONLY BE AVAILABLE AS AN ASSEMBLY